

Instructions for Cutler-Hammer Jockey Pump Controllers



TABLE OF CONTENTS

1. INSTALLATION AND MOUNTING OF THE CONTROLLER	1
2. SYSTEM PRESSURE CONNECTIONS	1
3. ELECTRICAL CONNECTIONS.....	1
3.1 ELECTRICAL CHECKOUT INSTRUCTIONS	2
3.1.1 <i>Motor Rotation Check</i>	2
3.1.2 <i>Pressure Switch Set Point</i>	2
3.1.3 <i>Starting and Stopping</i>	2
3.1.4 <i>Overload Relay Trip Setting</i>	2
3.1.5 <i>Running Period Timer (Optional)</i>	2
3.2 PRESSURE SWITCH SETTING INSTRUCTIONS.....	3
4. FIGURE 1: TYPICAL SCHEMATIC	4
5. FIGURE 2: DIMENSIONAL DRAWING	5
6. FIGURE 3: OVERLOAD RELAY SELECTION CHART.....	6

INSTALLATION & MAINTENANCE MANUAL FOR THE JOCKEY PUMP CONTROLLER

In order to familiarize yourself with the Jockey Pump Controller, please read the instruction manual thoroughly and carefully. Retain the manual for future reference.

1. Installation and Mounting of the Controller

Carefully unpack the controller and inspect thoroughly.

It is recommended that the controller is located as close as is practical to the motor it controls

The controller is not free standing and must be bolted securely to a wall. For dimensional and weight data please refer to the respective data sheets for the Jockey Pump Controller.

- Inspect all electrical connections, components and wiring for any visible damage and correct as necessary. Ensure that all electrical connections are tightened before energization.
- Install necessary conduit using proper methods and tools.
- Incoming AC line voltage is clearly marked L1, L2, L3 and ground, located at the top of the breaker.

2. System Pressure Connection

The Jockey Pump Controller is equipped with a Pressure Switch. The controller is provided with a 1/4" NPT female system pressure connection located on the bottom, external side of the enclosure. The connection should be installed as per NFPA, pamphlet No. 20.

NOTE: Water lines to the pressure switch must be free from dirt and contamination.

The pressure should not exceed what the pressure switch is rated for.

3. Electrical Connections

All electrical connections should meet national and local electrical codes and standards.

The controller should be located or so protected that they will not be damaged by water escaping from pumps or pump connections. Current carrying parts of controllers shall be a minimum of 12 inches (305 mm) above the floor level.

- Prior to starting verify all data on the nameplate such as, catalog number, AC line voltage and horsepower.

3.1 Electrical Checkout Instructions

WARNING: *The following procedures should be carried out by a qualified electrician familiar with the electrical safety procedures associated with this product and its associated equipment.*

- 3.1.1 Motor Rotation Check: With the controller energized, move the H.O.A. selector switch to "HAND" then back to "OFF" immediately to check the direction of the motor and pump rotation. If rotation direction is not correct, open the breaker and reverse the phase sequence of the load terminals of the contactor T1, T2, T3 or at the motor terminals.
- 3.1.2 Set up pressure switch set point as described on page 3 in these instructions. These instructions check out automatic starting and stopping.
- 3.1.3 Starting and Stopping: Energize the controller. With the H.O.A. selector switch set to "AUTO", if the system water pressure is lower than the pressure switch set-point pressure, the pump will start. The pump will stop when pressure is restored. If the optional running period timer is included, the pump will run for the set time and then reset provided pressure has been restored. For manual operation, set the H.O.A. selector switch to "HAND" to start the pump and "OFF" to stop.
- 3.1.4 Overload Relay Trip Setting: The trip setting must be set as indicated on the drawing inside the starter door or according to the chart at the back of this manual.
- 3.1.5 Running Period Timer: (Optional) The RPT timer must be set for a minimum of 10 minutes. A calibrated dial is provided on the front of the timer.

3.2 Pressure Switch Setting Instructions

Before attempting to set the pressure switch, de-energize the jockey pump controller by opening the Circuit Breaker. This is done for safety, and so that the jockey pump will not start and interfere with the adjustment procedure.

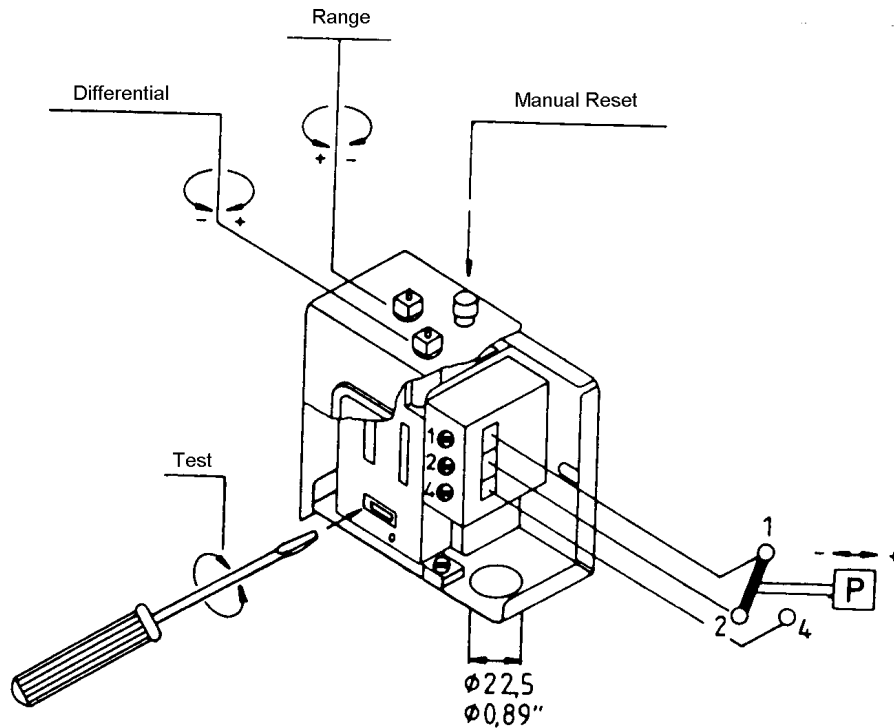

1. Set the differential adjustment on the pressure switch to minimum by turning the Differential Adjusting Screw fully counter clockwise. Set the operating pressure to well below the required pump starting pressure. Turn the Range Adjusting Screw clockwise to reduce the pressure and observe the scale on the switch.
2. Bleed the fire protection water system until the pressure is reduced to the required pump starting pressure. Hold this pressure by closing the drain valve.
3. Slowly rotate the Range Adjusting Screw counter clockwise until a click is heard from the pressure switch. The switch is now set to the required pump starting pressure.
4. If it is necessary to re-adjust the differential, the operating pressure of the switch will also be changed and should be reset.

NOTE: The cut-in (start point) pressure is the cut-out (range adjusting setting) pressure minus the differential setting.

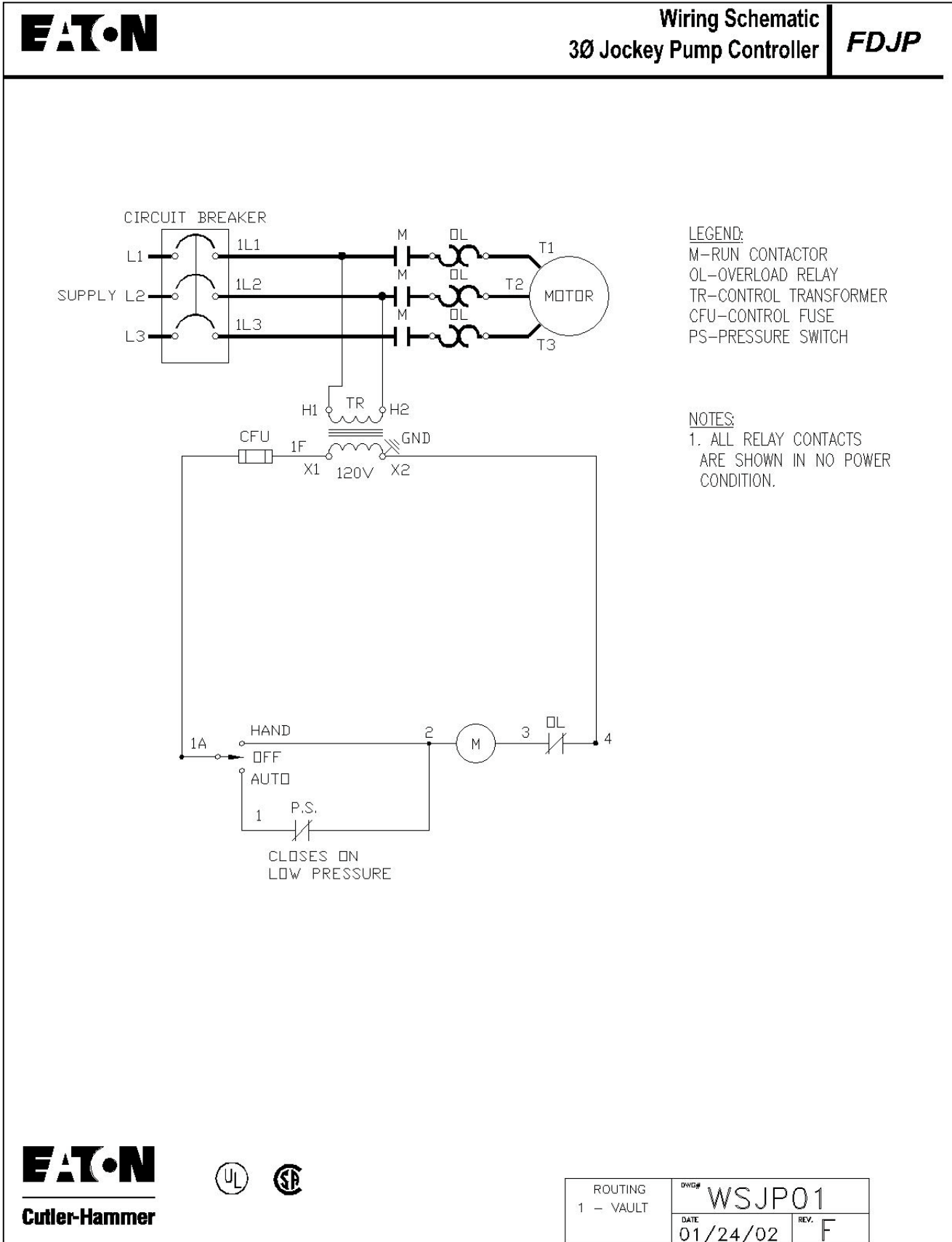

FIGURE # 1

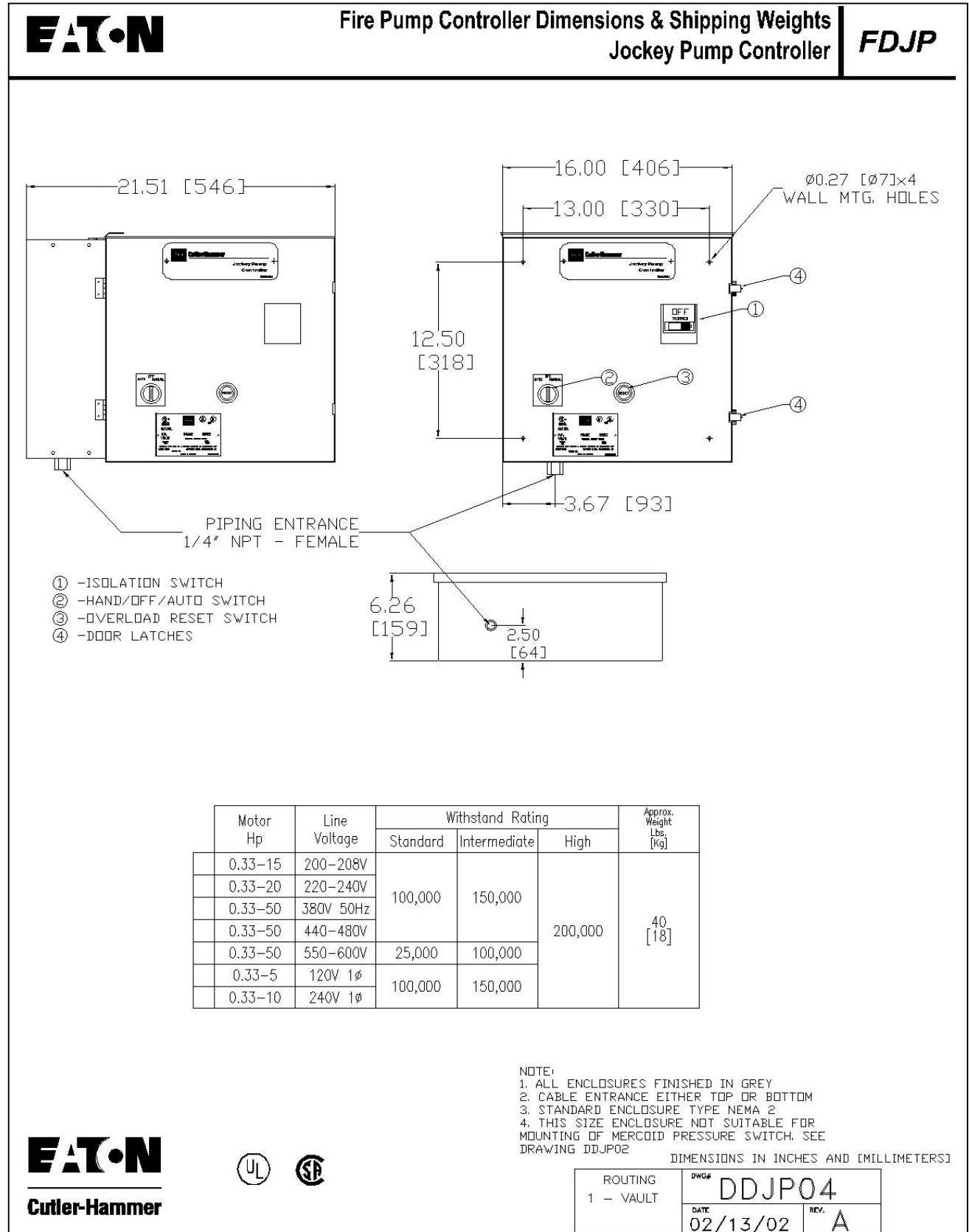

FIGURE # 2

OVERLOAD RELAY SELECTION CHART

TABLE A

JOCKEY PUMP CONTROLLER COMBINAITEURS DE POMPES DE MAINTIEN CATALOGUE FDJP 1800 RPM		
Code	ADJUSTMENT RANGE (Amps)	OVERLOAD RELAY STYLE
☐	NONE	-----
A	.25-.40	C316FNA3C
B	.40-.63	C316FNA3D
C	.63-1.0	C316FNA3E
D	1.0-1.4	C316FNA3F
E	1.3-1.8	C316FNA3G
F	1.7-2.4	C316FNA3H
G	2.2-3.1	C316FNA3J
H	2.8-4.0	C316FNA3K
J	3.5-5.0	C316FNA3L
K	4.5-6.5	C316FNA3M
L	6.0-8.5	C316FNA3N
M	7.5-11.0	C316FNA3P
N	10.0-14.0	C316FNA3Q
P	13.0-19.0	C316FNA3R
Q	18.0-24.0	C316FNA3S
R	22.0-32.0	C316KNA3B
S	29.0-42.0	C316KNA3C
T	36.0-52.0	C316KNA3D
U	45.0-63.0	C316KNA3E
V	24.0-32.0	(AMD)C316FNA3T

OVERLOAD RELAY SETTING

FOR MOTORS WITH 1.15 SERVICE FACTORS, SET OVERLOAD RELAY AT MOTOR FULL LOAD CURRENT.

FOR MOTORS WITH 1.0 SERVICE FACTOR, SET OVERLOAD RELAY AT 87% OF MOTOR FULL LOAD CURRENT.

REGLAGE DU RELAIS DE SURCHARGE

POUR LES MOTEURS AYANT UN FACTEUR DE SERVICE DE 1.15, AJUSTEZ LE RELAIS DE SURCHARGE POUR L'INTENSITE PLEINE CHARGE DU MOTEUR.

POUR LES MOTEURS AYANT UN FACTEUR DE SERVICE DE 1.0, AJUSTEZ LE RELAIS DE SURCHARGE A 87% DE L'INTENSITE PLEINE CHARGE DE MOTEUR.

MAX. HP RATING PER OVERLOAD RELAY CODE LETTER
LETTRE DU CODE PUISS MAX. EN HP DU RELAIS DE SURC.

HP	208 V		230 V		416 V		460 V		575 V	
	Motor Service Factor Facteur De Service Du Moteur									
	1.15	1.0	1.15	1.0	1.15	1.0	1.15	1.0	1.15	1.0
.33	F	-	F	-	C	-	C	-	B	-
.5	F	F	F	F	C	C	C	C	C	C
.75	G	G	G	G	E	D	D	E	C	C
1	J	H	J	G	F	E	E	E	E	D
1.5	K	K	L	J	G	F	G	G	F	E
2	L	K	K	K	H	H	H	G	G	F
3	M	M	M	M	K	J	J	J	H	H
5	P	N	P	N	M	L	L	K	K	K
7.5	R	R	Q	P	N	M	M	M	M	L
10	R	R	R	R	P	N	P	N	M	M
15	T	T	S	S	Q	Q	Q	P	P	P
20	U	U	T	T	R	R	R	R	Q	P
25	-	-	-	-	S	S	S	S	R	R
30	-	-	-	-	-	-	S	S	S	R

SINGLE PHASE	120 VOLTS		240 VOLTS	
	120 VOLTS	240 VOLTS	120 VOLTS	240 VOLTS
.25	5.8	2.9	K	G
.33	7.2	3.6	L	H
.5	9.8	4.9	M	K
.75	13.8	6.9	N	L
1	16.0	8.0	P	L
1.5	20.0	10.0	Q	M
2	24.0	12.0	V	N
3	34.0	17.0	S	P
5	56.0	28.0	U	R
7.5		40.0	-	S
10		50.0	-	T

1B01095H01

NOTES:

FOR SINGLE PHASE APPLICATIONS SELECT OVERLOAD RELAY AND CODE LETTER BASED ON FULL LOAD CURRENT OF THE MOTOR. SEE SINGLE PHASE TABLE AT RIGHT FOR FULL LOAD AMPS AND TABLE "A" FOR OVERLOAD CAT. No.

NOTE "*"

NO CONTROL TRANSFORMER

NOTE

380/415V 50HZ USE 416 O/L CHART

THE INFORMATION CONTAINED HEREON WHICH IS THE PROPERTY OF EATON YALE LTD. MUST BE MAINTAINED IN CONFIDENCE AND NO PORTION OF THIS DRAWING MAY BE REPRODUCED OR USED WITHOUT THE EXPRESS PERMISSION OF THE COMPANY.

FIGURE #3

EATON

Cutler-Hammer

403 East Lake Blvd., Airdrie, Alberta, T4A 2G1

Canada

tel: 403-948-7955

fax: 403-948-6967

www.chfire.com



Cutler-Hammer

© 2003 Eaton Corporation
All Rights Reserved
Printed in Canada
Publication No.: IM05805004K
January 2003